

MOD	LOC	DIST	P	F	ZONE	LTR	REVISIONS	DESCRIPTION	DATE	APPD
5	GP	00					0	RLSE NPR 5102, WAS 94-4163-024-10	07/11/94	-
							A	REV PER EC 0020-1252-94	10/17/94	RF
							B	REV PER EC 0020-1525-94	02/02/95	RF
							C	REV PER EC 051A-0168-00	06/28/00	NF

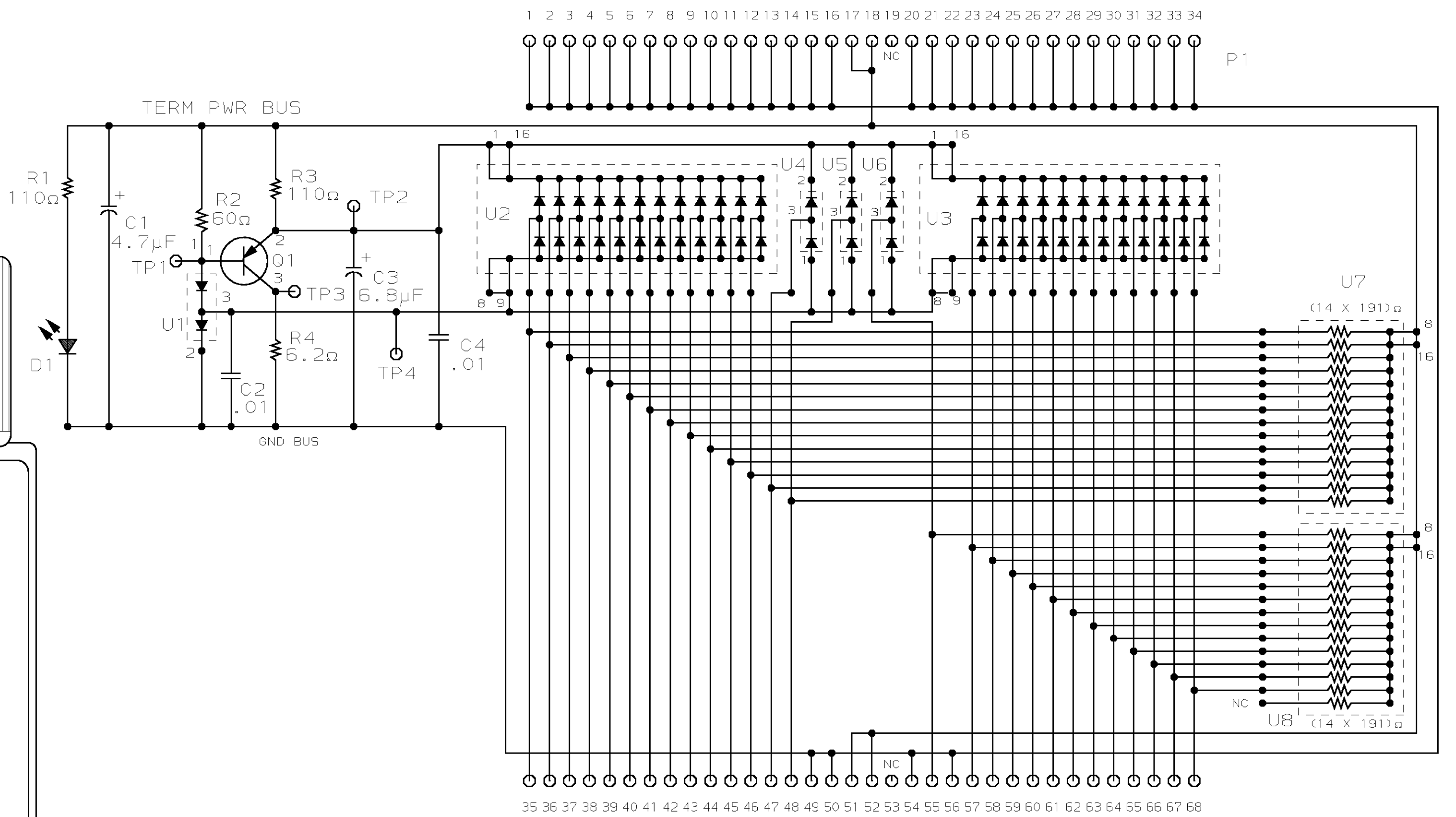
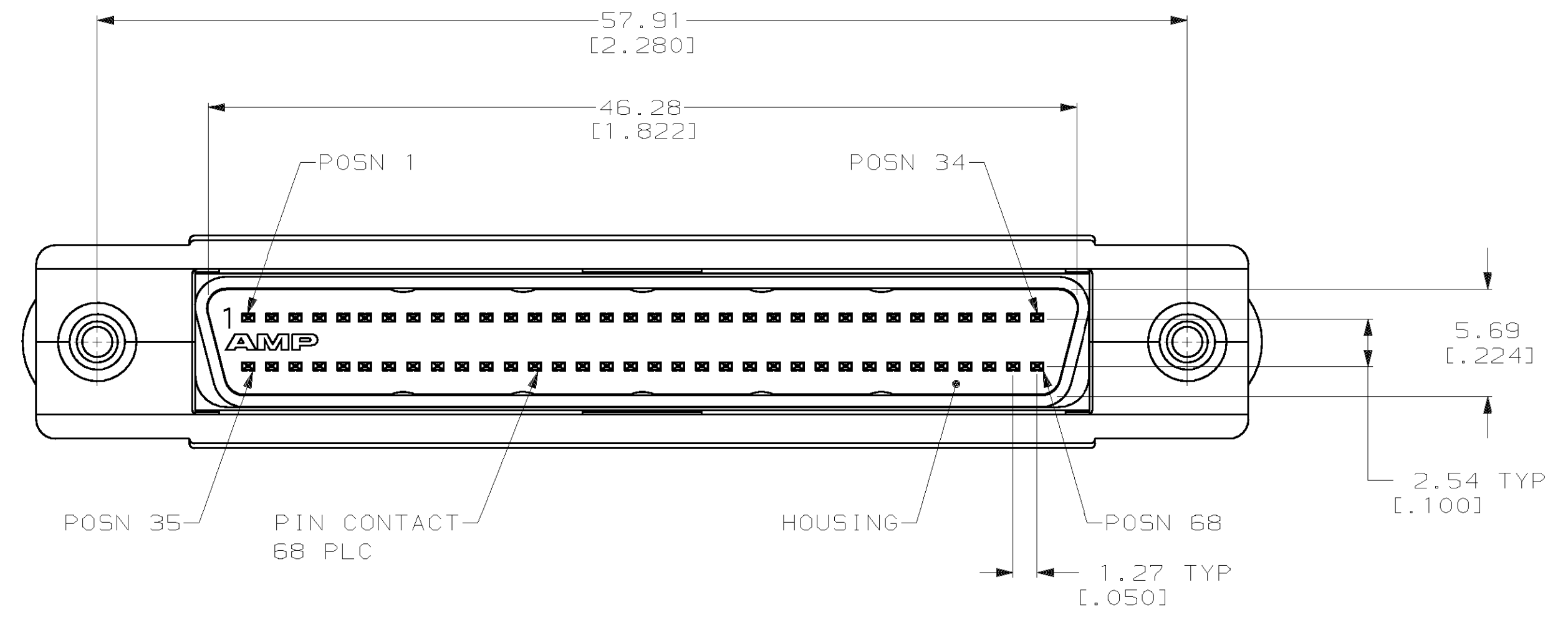
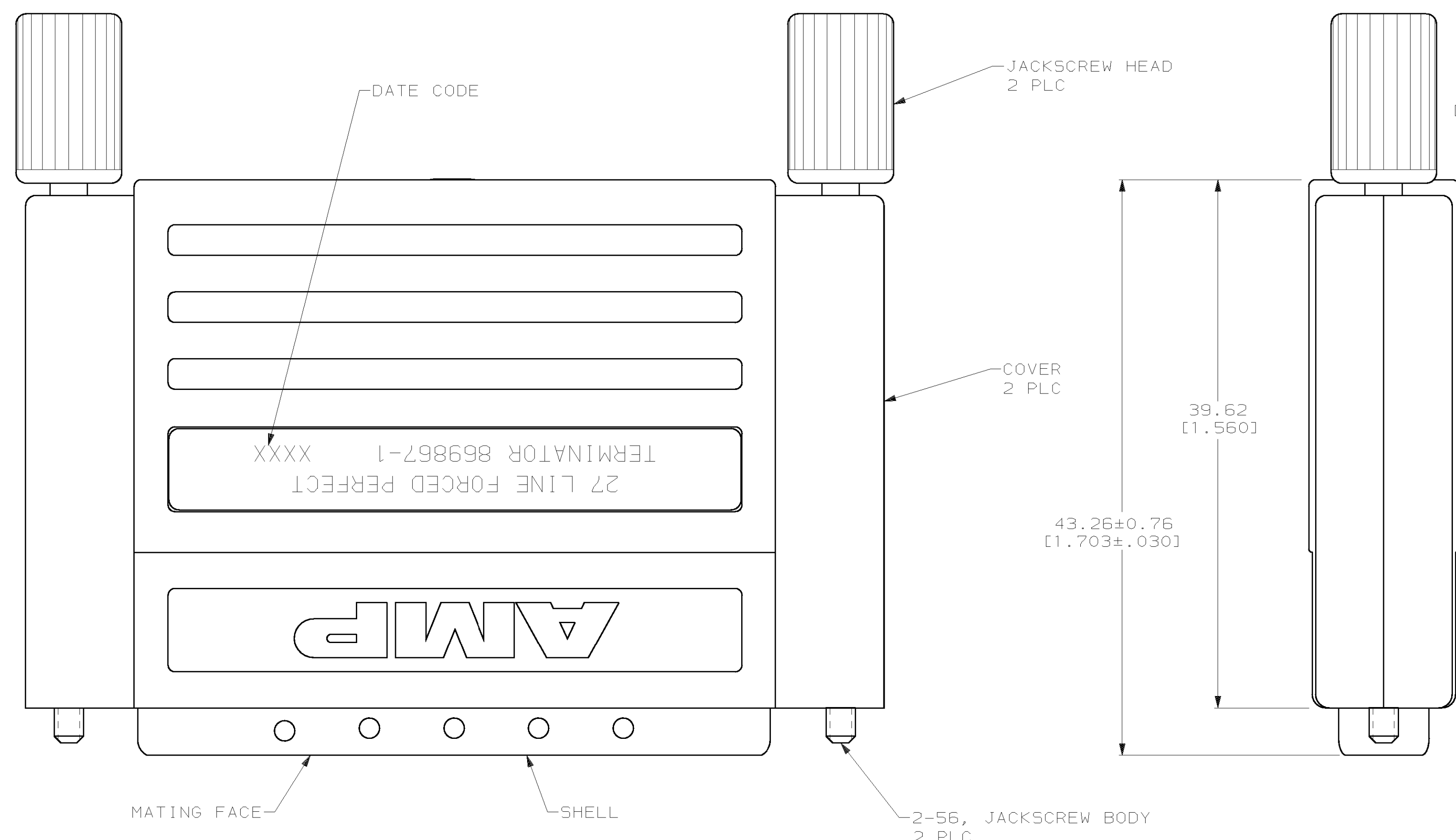
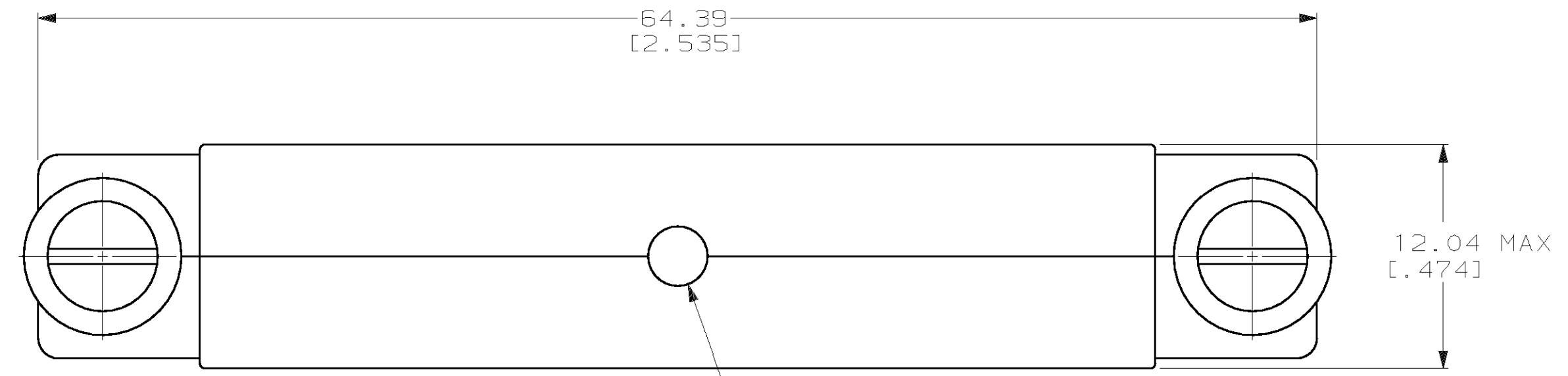

△ SHELL: CARBON STEEL; PIN CONTACT: PHOSPHOR BRONZE; HOUSING: POLYESTER, BLACK; PCB= FR-4 COPPERCLAD WITH SURFACE MOUNTED COMPONENTS ON TWO SIDES. JACKSCREW BODY: STAINLESS STEEL; JACKSCREW HEAD: PVC, BEIGE; COVER: ABS; SHIELD: COPPER.  
 △ 5.08µm[.000200] MIN TIN-NICKEL OVER 1.27µm[.000050] MIN COPPER.  
 △ 0.76µm[.000030] MIN GOLD FOR A LENGTH OF 3.35[.132] MIN FROM MATING END OVER 1.27µm[.000050] MIN NICKEL.

DO NOT SCALE PRINT. UNLESS SPECIFIED DIMENSIONS IN mm [INCHES] TOLERANCES ON: 2 PLC DEC ± 0.25 [0.010] 3 PLC DEC ± ANGLES ±		DR 07/11/94 W.G.LENKER CHK 10/19/94 R.STONE APPD 10/19/94 R.FOWLER APPD 10/19/94 R.FOWLER PRODUCT SPEC APPLICATION SPEC WEIGHT	<b>AMP</b> AMP Incorporated Harrisburg, PA 17105-3608 NAME PLUG ASSEMBLY, 68 POSITION, 27 LINE F.P.T., .050 SERIES AMPLIMITE™, TERMINATOR	
FINISH SHELL: △ CONTACTS: △	MATERIAL △		SIZE D	CAGE CODE 00779
			DRAWING NO C-869867	
			SCALE 4:1	SHEET 1 OF 1

THIS DRAWING IS A CONTROLLED DOCUMENT FOR AMP INCORPORATED. IT IS SUBJECT TO CHANGE AND THE CONTROLLING ENGINEERING ORGANIZATION SHOULD BE CONTACTED FOR THE LATEST REVISION.